

## HA 16 SPX HA 18 SPX



- Max. 34 ft 9 in (10.60 m) horizontal outreach (HA18SPX).
- 40% gradeability.
- 1 ft 2 in (38 cm) ground clearance.
- 4 wheel drive.
- Soft, proportional and simultaneous movements.



# HA 16 SPX HA 18 SPX

# Articulating booms

## The Haulotte® advantages

- 52 ft and 57 ft (16 and 18 m) working heights
- Hydraulic differential lock and 1 ft 2 in (38 cm) ground clearance for improved rough terrain capability
- Gradeability up to 40%
- 45 sec. lift speed to full height
- Full proportional controls and simultaneous boom functions improve productivity
- Load control in cage
- Improved working area through a positive / negative articulating fly jib with 140° movement
- Zero tailswing
- 180° hydraulic platform rotation
- Improved design for travel / transport (HA 16 SPX: 5.25 m / 17 ft 3 in transport length)
- Robust, reliable and easy to maintain design
- Improved security due to load limiter in the basket

## STANDARD FEATURES

- 4 wheel drive and 2 wheel steering
- 55 l (15gal) fuel tank
- Tilt alarm
- 12 V battery / electrical control system
- Electric emergency group in cage
- Free wheeling device
- Hourmeter
- Slewing block pin
- Towing hooks / lifting eyes

## OPTIONS & ACCESSORIES

- 230 V / 115 V - 16 A power line in cage
- Travel alarm
- Rotating beacon
- Working light
- Catalytic exhaust
- Encoded starting device
- Biodegradable hydraulic oil
- Cold countries kit
- Hot countries kit

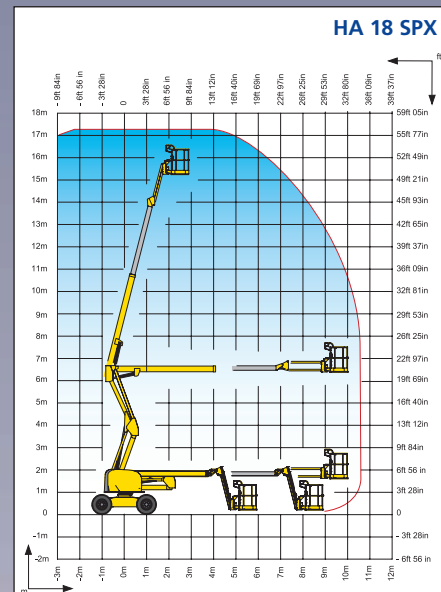
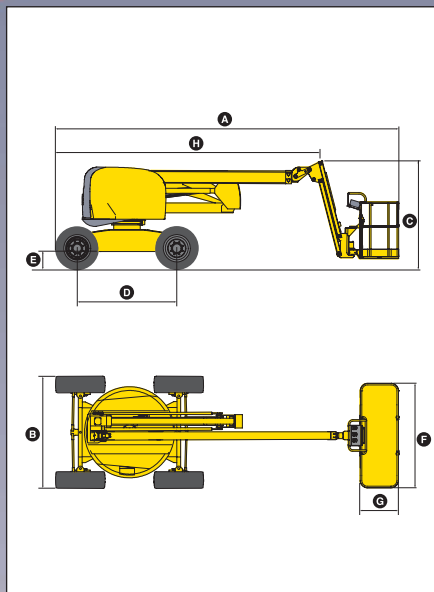

## SPECIFICATIONS

	HA 16 SPX		HA 18 SPX	
Working height	16.0 m	52 ft	17.3 m	56 ft 2 in
Platform height	14.0 m	46 ft	15.3 m	50 ft 2 in
Maximum outreach	9.1 m	29 ft 10 in	10.60 m	34 ft 9 in
Up and over clearance	6.60 m / 21 ft 8 in			
Platform capacity	230 kg / 507 lb			
Fly jib range of motion	140° (+70° / -70°)			
<b>A</b> Stowed length	6.65 m	22 ft 4 in	7.50 m	24 ft 7 in
<b>B</b> Width	2.25 m / 7 ft 7 in			
<b>C</b> Stowed height	2.20 m / 7 ft 3 in			
<b>D</b> Wheelbase	2.0 m / 6 ft 7 in			
<b>E</b> Ground clearance	38 cm / 14 in			
<b>F</b> x <b>G</b> platform size	1.8 m x 0.8 m / 71 in x 32 in			
Travel / transport length	5.25 m	17 ft 3 in	5.80 m	19 ft
Travel / transport height	2.16 m / 7 ft 1 in			
Tailswing	0			
Drive speed	1.5 / 5.5 km/h		0.9 / 3.7 mph	
Outside turning radius	4 m / 30 ft 6 in			
Inside turning radius	2 m / 11 ft 8 in			
Turntable rotation	350°			
Hydraulic platform rotation	180°			
Engine	Deutz Diesel 31 kW / 42hp			
Gradeability	40%			
Tyres (foam filled)	350 - 14 - 17,5			
Hydraulic tank	100 l / 26 gal			
Fuel tank	55 l / 15 gal			
Weight	6.850 kg	14.553 lb	7.950 kg	16.538 lb

AS1418.10



HAULOTTE UK LTD • STAFFORD PARK 6 • TELFORD - SHROPSHIRE TF3 3AT • TEL: +44 (0)1952 292753 • FAX: +44 (0)1952 292758 • E-mail: haulotte@haulotte.com  
 HAULOTTE SCANDINAVIA AB • ARÖDS INDUSTRIVÄG 66 B • 422 43 HISINGS BACKA - SWEDEN • TEL: +46 31 744 32 90 • FAX: +46 31 744 32 99 • E-mail: hwallin@haulotte.se • www.haulotte.se  
 HAULOTTE AUSTRALIA PTY LTD • 65 LICOLA CRES • DANDENONG - VIC - 3175 • TEL: +61 (0)3 9706 6787 • FAX: +61 (0)3 9706 6797 • E-mail: sales@haulotte.com.au  
 HAULOTTE SINGAPORE PTE. LTD • 26 Changi North Road Way • SINGAPORE 498812 • TEL: +65 6536 3989 • FAX: +65 6536 3969 • E-mail: haulotteasia@haulotte.com

